



FEATURES LM OG-I

- Leakproof, magnetic drive
- Large LCD display
- Three decimal point precision
- Totalization in gallons or liters
- Delivery in pints, quarts, liters or gallons
- Only two parts to reduce maintenance costs
- Accuracy to $\pm 0.5\%$ (linearisation possible)
- About 4 years battery life
- Low battery indicator
- Replaceable battery
- Battery shelf life – 10 years
- Humidity and moisture resistant register
- Two year limited warranty
- Not for use in Ex-zone



DESCRIPTION LM OG-I

The electronic lube meter is designed specifically to dispense motor oils, gear oils, automatic transmission fluid, engine coolant (Ethylene Glycol) brake fluid, diesel and windshield wiper fluid solutions. Modular design, low cost, light weight and rugged make the OG the best choice for overhead reel systems.

DESCRIPTION LM OG-TI

The meter with pulse transmitter, model LM OG-TI, is an economical, rugged yet accurate meter. The transmitter, mounted on the meter, can be wired to batch controllers, remote counters and other electronically operated instruments that can accept pulses from a reed switch. The oval gear transmitter is contained in a glass filled plastic housing with a NEMA 4X rating.

FEATURES LM OG-TI

- Does not require external power
- Rugged, corrosion resistant plastic enclosure
- Watertight, NEMA 4X housing
- Compatible with most flow controllers and counters
- Humidity and moisture resistant transmitter
- Maximum operating pressure 100 bar
- For use in Ex-zone 1 (with suitable drive)



APPLICATIONS

The electronic register module contains a micro-processor board powered by a lithium battery with an expected life of 4 years depending on use. It can be programmed to dispense in pints, quarts, liters, or gallons. A calibration factor and unit of measure are programmed during factory test. Unlike mechanical meters, these units can be electronically recalibrated in the field when necessary. A 6-digit liquid crystal display, accurate to the second decimal place, shows the exact amount of fluid dispensed. The entire register module is protected from the wear and tear of normal shop use by a rugged, glass filled, shock resistant, nylon housing.

OPERATION

As fluid passes through the metering chamber by entering the inlet port, it forces the internal gears to rotate and exits through the outlet port. Each rotation of the gear displaces a given volume of fluid. Controlled clearances between the gears and chamber wall insure minimum leakage. As the gears rotate, a magnet on each end of the gear activates the microprocessor in the register. The ILR displays have a resettable and a non-resettable totalizer; actual flow rate can be shown in l/min.

CAUTION: THE USE OF METERS IN APPLICATIONS OTHER THAN THOSE DESCRIBED IN THIS BULLETIN MAY RESULT IN INACCURACY AND POSSIBLE METER FAILURE.

DIMENSIONS (MM)

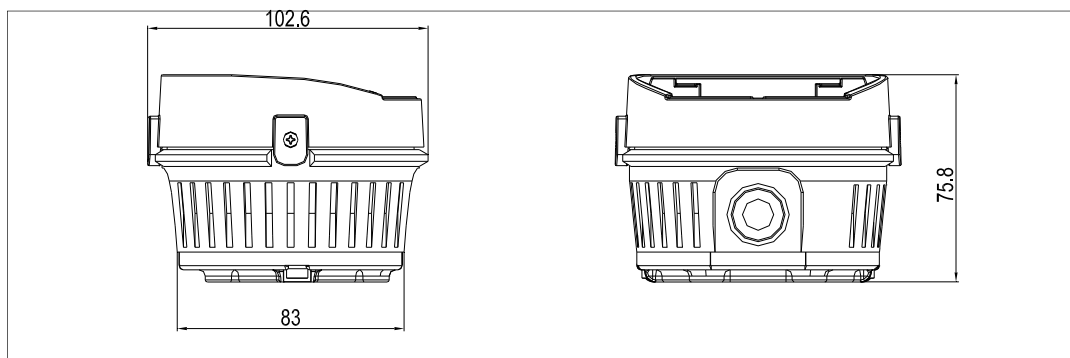

TECHNICAL DATA

Type	LM OG-I	LM OG-I SS	LM OG-TI
Flow rate *	0,5 - 35 l/min		
Operating pressure	0,35 - 100 bar		
Operating temperature	-20°C to +80°C		
Accuracy t	±0.5%		
Pulses per liter	-	-	100
Weight, less handle	1.0 kg	1,5 kg	0.9 kg
Display	6-digit LCD display	6-digit LCD display	-
Inlet & outlet connections	½" BSPP		

* Tested with Mobil DTE-25 motor oil at ambient temperature. Min./max. flow rates will vary with fluid viscosity.

MATERIALS

Typ	LM OG-I	LM OG-I SS	LM OG-TI
Housing	Aluminium	Stainless steel 1.4301	Cast aluminium with hardcoat black anodize per Mil 8625 III Class 2
Oval gear meters	Vectra (LCP-plastic)	Vectra (LCP-plastic)	LCP (Liquid Crystal Polymer)
Pulse housing	-	-	Fiber-glass reinforced Nylon
O-ring	Viton (Kalrez optional)	Viton (Kalrez optional)	Viton

OVAL GEAR PRESSURE DROP VS FLOW RATE FOR VARIOUS FLUIDS

Viscosities in centistokes (11-19-96)

